

XL-HCW224C
Coax MDU
Master Bridge

Quick Start Guide

Version 1.1

Dec. 2009

Packing List

The contents,

- ◆ One Main Unit (the Bridge)
- ◆ One DC 12V Power Adapter
- ◆ One F-Type Male-to-Male Coaxial Cable
- ◆ One RJ-45 Ethernet Cable

Front Panel

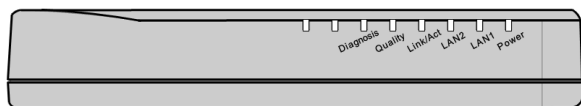

LED Indicators

1. **Power:** Lighting up when power on.
2. **LAN1:** Dual led. Green led is up when LAN1 port is active, and flashing while there is any data traffic. Extra Orange led will be on if LAN1 links in 1Gbps.
3. **LAN2:** Dual led. Like led LAN1.
4. **Link/Act:** Lighting up when HCNA port is active, and flashing when there is any data traffic.
5. **Quality:** Dual led. Shows in Green/Orange/Red for respected High/Medium/Low average HCNA speed.
6. **Diagnosis:** Lighting up when master is diagnosing HCNA connection toward/from EP.

Rear Panel

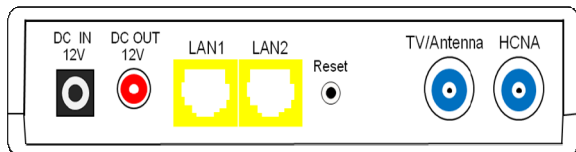

Connectors & Button

1. **DC IN 12V:** Connect to the power adapter plug.
2. **DC OUT 12V:** Provide maximum 1Amp powering while master runs in **Line Power** mode.
3. **LAN1/LAN2:** Two Gigabit Ethernet ports to connect uplink Switch/FTTx/PON/xDSL Modem.
4. **Reset:** While master is on, press and release this button will reboot master. Press it for lasting 5 seconds will restore all settings to factory default. For example, the IP address will restore to default '**192.168.1.1**'.
5. **TV/Antenna:** Connect to TV Set. Or connect to VHF/UHF antenna or CATV to bypass TV signal to HCNA port.
6. **HCNA:** Attach to existing coaxial cable and use it as the networking backbone in one or more MDUs. **xl-hcw224c** is the **Master** device and controls the other **Slave** HCNA devices (refer to Endpoint or **EP**) on the same coax network.

Side Switch

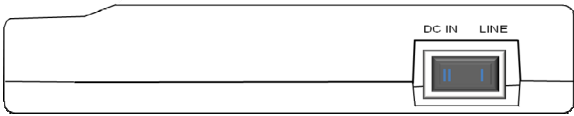

Rocker Switch

1. **DC IN:** Runs in **Local Power** mode, powering master via DC adapter plug.
2. **LINE:** Runs in **Line Power** mode, powering master via the coax cable connected to port 'HCNA'. (Port 'HCNA' holds both data and power).

Connecting the Cables

Example 1:

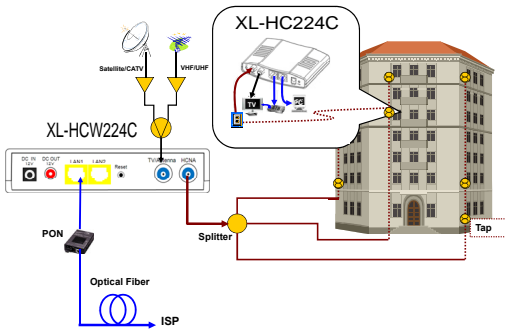

Note: The minimum attenuation between Master and EP is 15 dB.

Example 2:

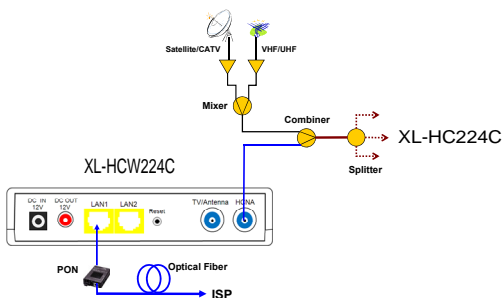

Configure by Web Browser

The factory default IP address of master is '192.168.1.1' and the default subnet mask is '255.255.255.0'. To access the bridge with default IP, your PC should be within the same IPv4 network as the bridge master. That is, your PC's IP address should be as "192.168.1.xxx". For instance, you may connect your PC with the bridge directly by one Ethernet cable between your PC's Ethernet adapter and bridge's port LAN1. Also configures your PC's TCP/IP setting to fixed IP as "192.168.1.xxx", subnet mask as "255.255.255.0", disable DHCP option. Make your PC and the bridge within the same "192.168.1.xxx" network. Type in **192.168.1.1** in your browser's website navigating field, as the following,

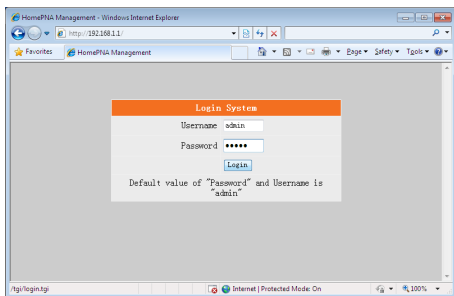

The bridge will prompt you a window for authorization. The factory default **Username** is '**admin**', also **Password** is '**admin**'. Please change it to a more secured password after you login successfully. Here shows the main configuration menus after login,

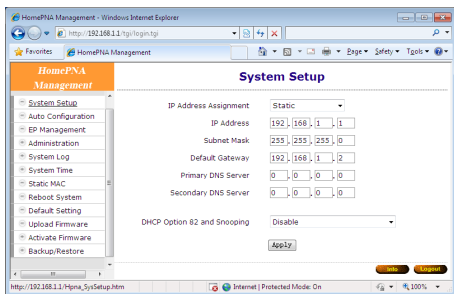

The main window contains the left sub-window for the items to be configured, and the right sub-window displays the contents for the selected item. Click your mouse on the item in the left window will pop out the corresponding item-window in the right side. Click on the '**Apply**' button (or '**OK**' button) will submit your new settings into the bridge and will take effect immediately.

Troubleshooting

Please check this simple troubleshooting before contacting with your service provider.

The Power LED is off:

- *Make sure the power adapter is properly plugged into a live electrical outlet.*

The LAN or Link/Act (HCNA) LED is off:

- *Make sure the connection of such ports is secure.*
- *The Ethernet device or EP device to which you are connected should be powered on and properly configured.*

The HCNA Quality LED is low (red):

- *Check the physical connection quality between the bridge and each EP by diagnosis tools embedded in the bridge (click ‘Test’ button).*

Can not transmit/receive data between bridge and EPs:

- *Make sure they are properly powered and all the cables are connected properly.*
- *Check the configuration settings in the bridge,*
 - *Bridge and EP have the same “Privacy Key”.*
 - *“Host Limit” for each EP is not zero.*
 - *“HPNA” port for each EP is not disabled.*

For unmatched “Privacy Key”, it is not possible to send/receive data between the bridge and each

EP. (Web browser shows red background for unmatched EP row in “EP Management” configuration window).

If “Host Limit” of EP is 0 (zero) or “HPNA” port is disabled, the EP is not allowed to send/receive data.

- *Check the physical connection quality between the bridge and each EP by diagnosis tools.*
- *If the connection quality is not good enough, please review the whole coax segment,*
 - *Wiring topology: not across amplifier.*
 - *Total path attenuation: including mixer, combiner, splitter and tap.*
 - *Noise sources: as cannot co-exist with DOCSIS signal.*
- *Check the Firmware version of the bridge and EPs.*

Can not transmit/receive data between EPs:

- *For security, it is intentionally designed to block the communication between EPs.*

Can not reach high speed communication:

- *Please check the settings of bandwidth control, or the maximal throughput of your WAN service.*
- *Please check your physical connection quality.*
- *Consult with your service provider for potential specific-application-optimized Firmware.*